

MOUNTAINVIEW ROAD

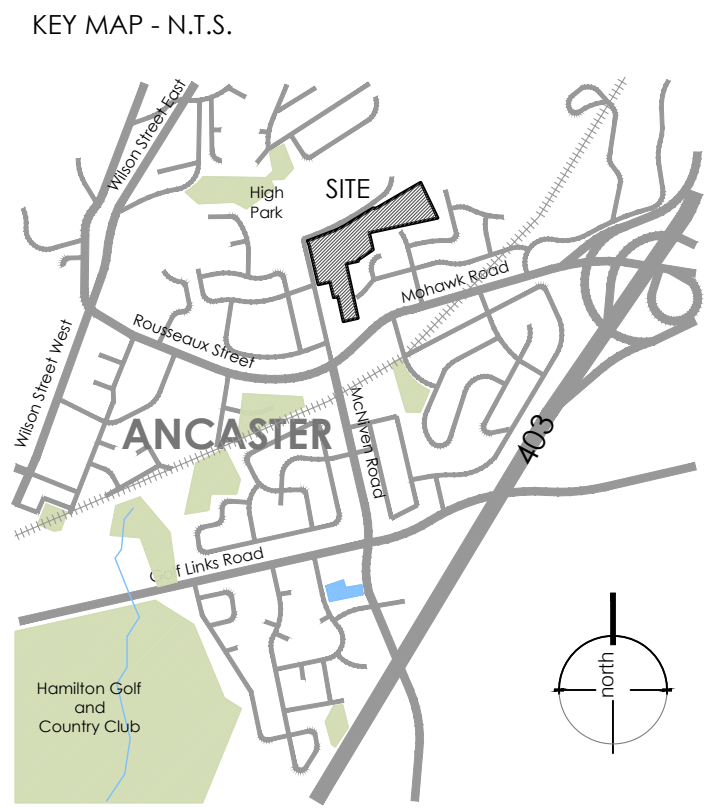
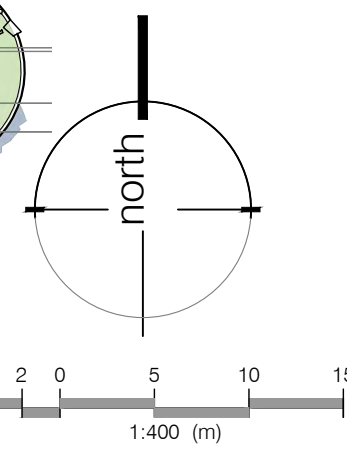

- LEGEND**
- property line
 - existing tree to remain
 - ⊕ proposed deciduous tree
 - ⊙ proposed shrub
 - ⊗ proposed perennial
 - min. 150mm topsoil, fine grade & sod
 - C.I.P. concrete
 - precast concrete unit pavers

REVISIONS/ SUBMISSIONS

#	DATE	DESCRIPTION
1	2024-10-10	Issued for Coordination
2	2024-11-18	Issued for Submission



CLIENT
Municipality
Halton Hills

PROJECT
130 Mountain View Road
Georgetown, Halton Hills
Ontario

MUNICIPAL FILE NUMBER

SHEET
Landscape Concept **L-1**

adesso design inc.
landscape architecture

69 John Street South, Suite 250
Hamilton, ON L8N 2B9
1.905.526.8876
www.adessodesigninc.ca

1/24/24: Project No. 24-016, 130 Mountain View Road, Ancaster, Ontario. Prepared by Adesso Design Inc. for the Municipality of Halton Hills. All rights reserved. No part of this drawing may be reproduced without the written permission of Adesso Design Inc. 2024-11-18. 1:400. 1/24/24: Project No. 24-016, 130 Mountain View Road, Ancaster, Ontario. Prepared by Adesso Design Inc. for the Municipality of Halton Hills. All rights reserved. No part of this drawing may be reproduced without the written permission of Adesso Design Inc. 2024-11-18. 1:400.

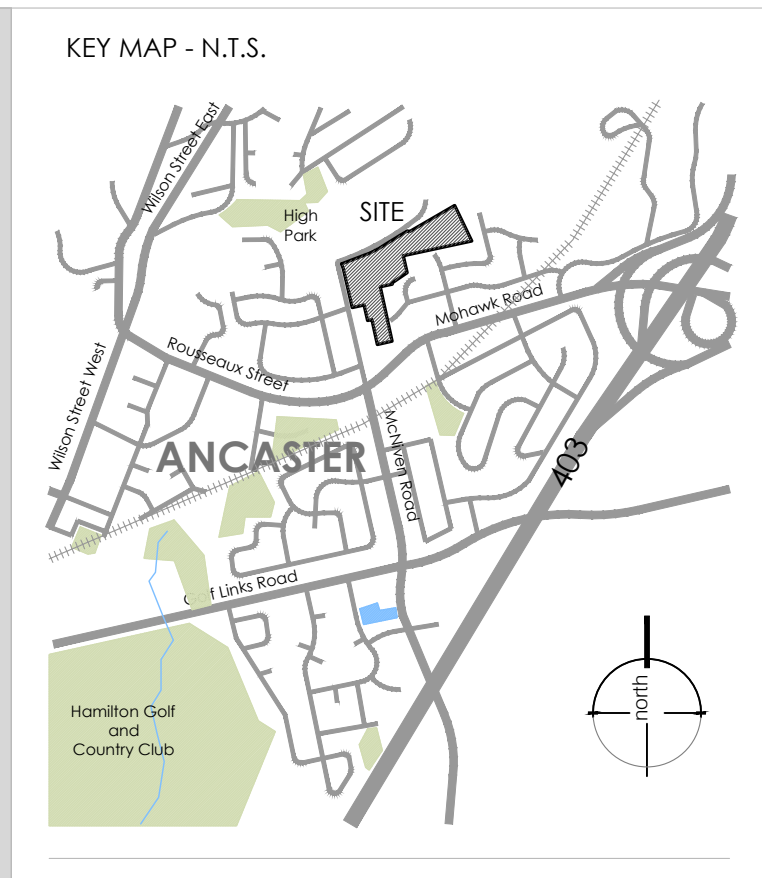
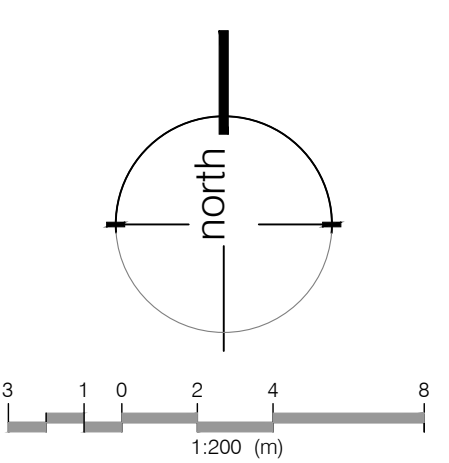
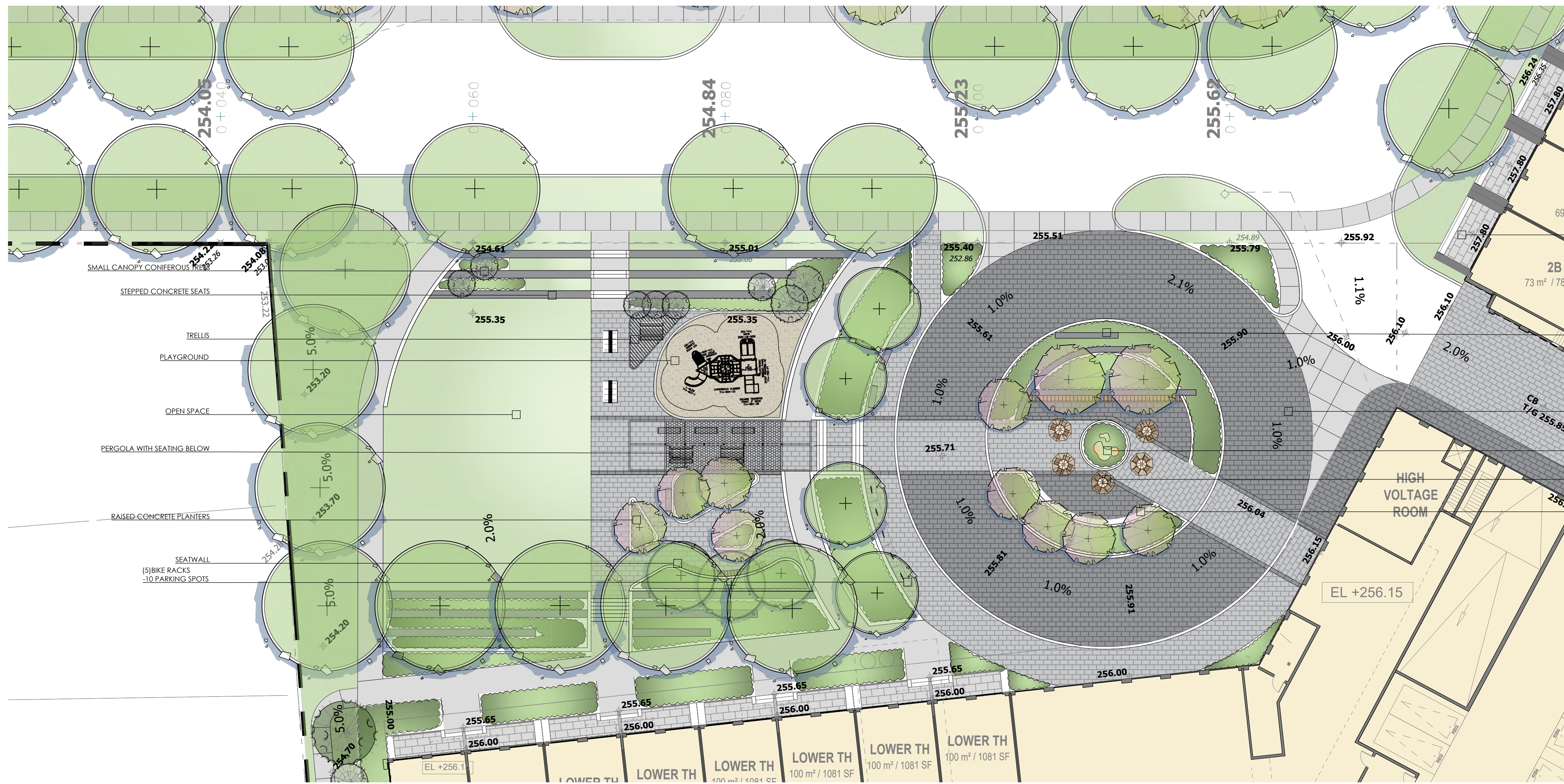

LEGEND

- - - - - property line
- (circle with cross) existing tree to remain
- (circle with dot) proposed deciduous tree
- (circle) proposed shrub
- (plant icon) proposed perennial
- (green box) min. 150mm topsoil, fine grade & sod
- (grey box) C.I.P. concrete
- (brick icon) precast concrete unit pavers
- (dashed line) PRIVATE PATIOS
- (arrow) ENTRY SIGN
- (square) PRECAST CONCRETE PAVERS
- (star) ART FEATURE
- (table icon) DINING TABLES WITH UMBRELLAS
- (bench icon) BENCHES

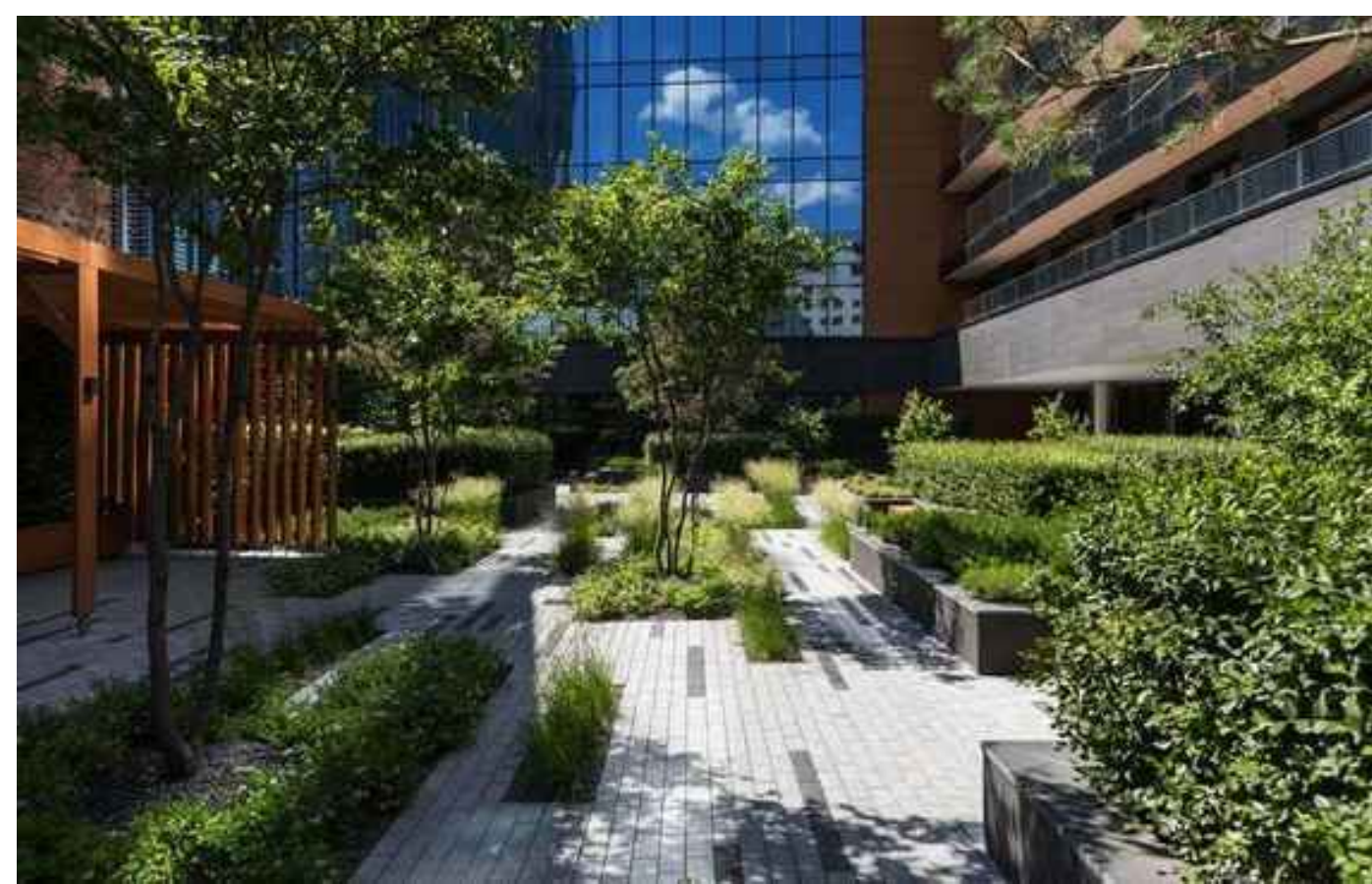
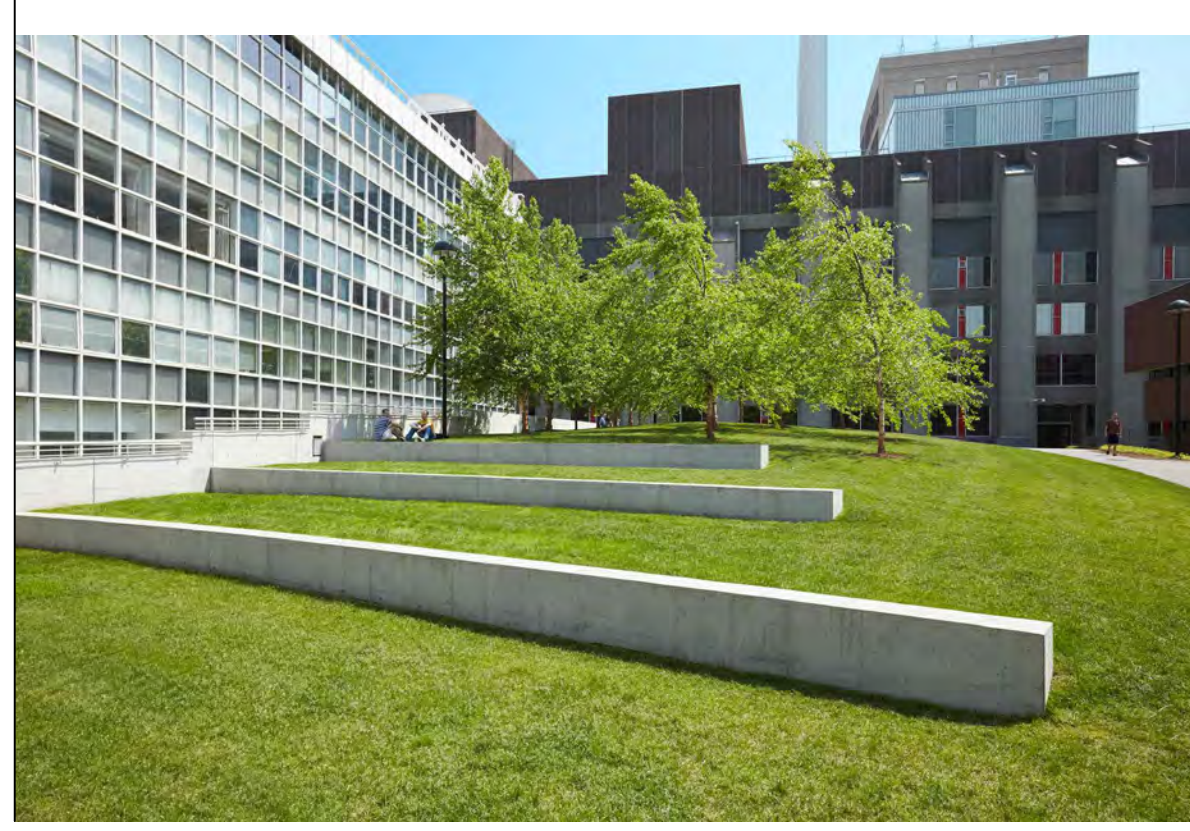
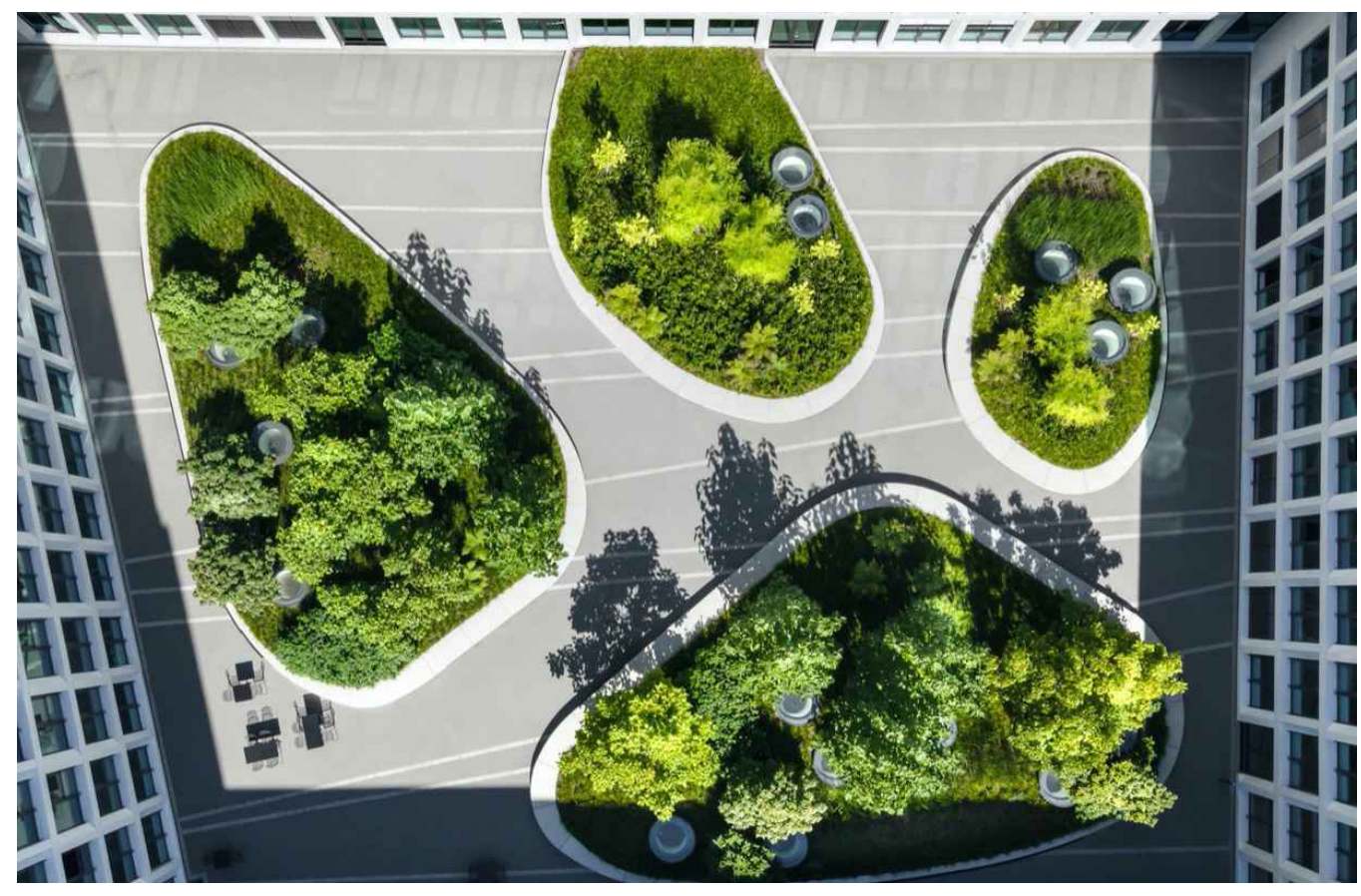

REVISIONS/ SUBMISSIONS

#	DATE	DESCRIPTION
1	2024-10-10	Issued for Coordination
2	2024-11-18	Issued for Submission

STAMP



CLIENT

Municipality
Halton Hills

PROJECT

130 Mountain View Road
Georgetown, Halton Hills
Ontario

MUNICIPAL FILE NUMBER

SHEET

Amenity Enlargement

L-2

adesso design inc.
landscape architecture

69 John Street South, Suite 250
Hamilton, ON L8N 2B9
1.905.526.8876
www.adessodesigninc.ca

OALA Member # 22678
 10/10/24, 10:20 AM
 2024-10-10
 10/10/24, 10:20 AM
 2024-11-18
 10/10/24, 10:20 AM
 2024-11-18
 10/10/24, 10:20 AM
 2024-11-18